

THIS DRAWING IS UNPUBLISHED. RELEASED FOR PUBLICATION, 19 .  
 © COPYRIGHT 19 BY AMP INCORPORATED. ALL RIGHTS RESERVED.

LOC	DIST	REVISIONS			
P	LTR	DESCRIPTION	DATE	DWN	APVD
AF	50	K	REV PER OG3A-0679-03	27OCT03	JR DD

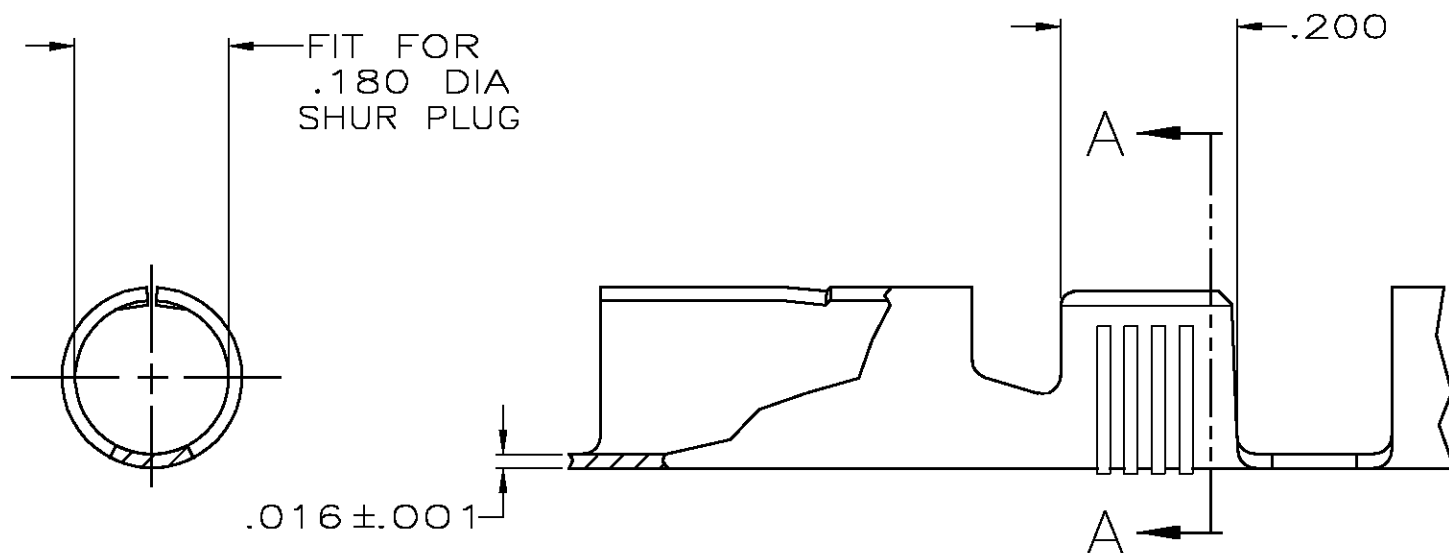

- 1 CONTINUOUS STRIP ON REELS.
- △2 .000080 MIN TIN PLATE.
- △3 .000080 MIN TIN PLATE OVER .000050 MIN NICKEL UNDERPLATE.
- △4 .000150 MIN NICKEL PLATE
- △5 PRELIMINARY - NOT FOR PRODUCTION

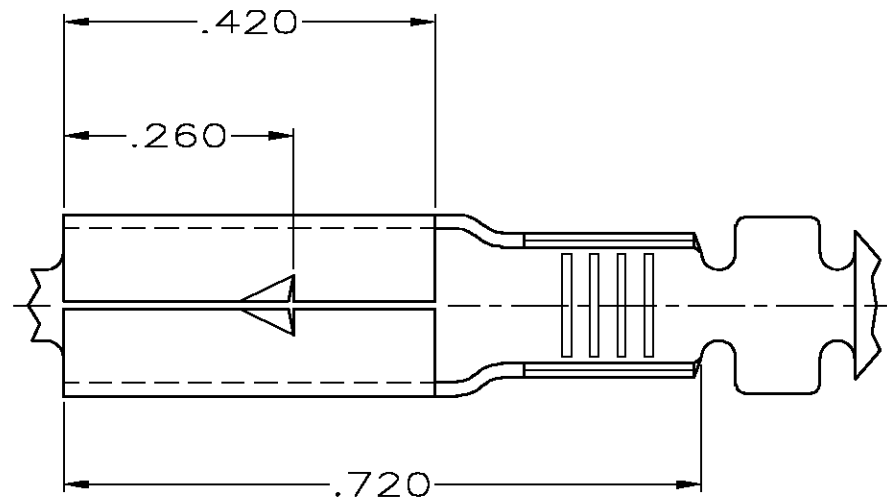
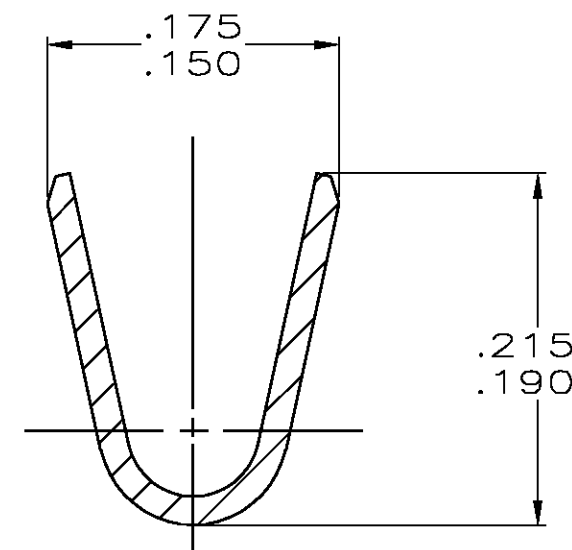

SECTION A-A  
SCALE 10:1

△4	14-10 AWG	△5	42868-4
△3	14-10 AWG		42868-3
△2	14-10 AWG		42868-2
-	14-10 AWG		42868-1
FINISH		WIRE RANGE	
		PART NUMBER	

THIS DRAWING IS A CONTROLLED DOCUMENT.		DWN	12JUL2001	AMP Incorporated	
		CHK	12JUL2001	Harrisburg, PA 17105-3608	
		APVD	12JUL2001	NAME	
		PRODUCT SPEC		RECEPTACLE, SHUR PLUG, .180 DIA	
		APPLICATION SPEC		SIZE	CAGE CODE
		WEIGHT		A3	00779
		CUSTOMER DRAWING		DRAWING NO	42868
				RESTRICTED TO	-
				SCALE	5:1
				SHEET	1 OF 1
				REV	K

DIMENSIONS:	TOLERANCES UNLESS OTHERWISE SPECIFIED:
INCHES	
	0 PLC ±-
	1 PLC ±-
	2 PLC ±-
	3 PLC ±.010
	4 PLC ±-
	ANGLES ±-
MATERIAL	FINISH
4M BRASS	SEE TABLE